

Model
6200T
Total Sulfur Analyzer
UV-Fluorescence Technology

FEATURES

- Large color touch-screen provides large, luminescent interface
- Two ranges, 0-50 ppb to 0-20 ppm, user-selectable
- USB ports on front panel for peripheral devices and firmware upgrades
- Adaptive signal filtering optimizes response time
- Temperature and pressure compensated
- Internal data-logging of most operating parameters, user-configurable



MODEL 6200T - TOTAL SULFUR ANALYZER

The need to continuously detect for sulfur in carbon dioxide has become increasingly important within the food and beverage market.

Gas suppliers must ensure that the CO₂ they provide for use in the preservation of food and drink related products meet today's exacting standards. The contamination of carbon dioxide can emanate from many sources and therefore it is essential that the CO₂ used for such purposes be monitored at the CO₂ generator facility, at the beverage producer facility, or both.

PRINCIPLE OF OPERATION

The Model 6200T Total Sulfur Analyzer utilizes proven UV fluorescent technology to continuously detect sulfur found in inert gas streams. An internal, quartz catalytic converter is employed to convert the sulfur, when mixed with scrubbed ambient air, into SO₂ via high temperature oxidation.

An internal vacuum pump is employed to draw both the sample and the ambient air into the converter. The converted sample gas is fed to the fluorescence chamber where it is then exposed to ultra-violet radiation.

The measurement process in the reaction cell is described by the following equation:

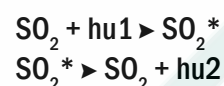

Where hu1 is the incident UV energy at 214nm and hu2 is the resultant fluorescence, which is directly proportional to the SO₂ concentration in the reaction cell.

The fluorescence emission is in turn sensed by the photomultiplier tube (PMT) and amplified to provide an analog output. The result is a continuous measurement of total sulfur (i.e. H₂S, CS₂, COS, mercaptans, etc.) as SO₂ from 0-50 ppb to 0-20 ppm.

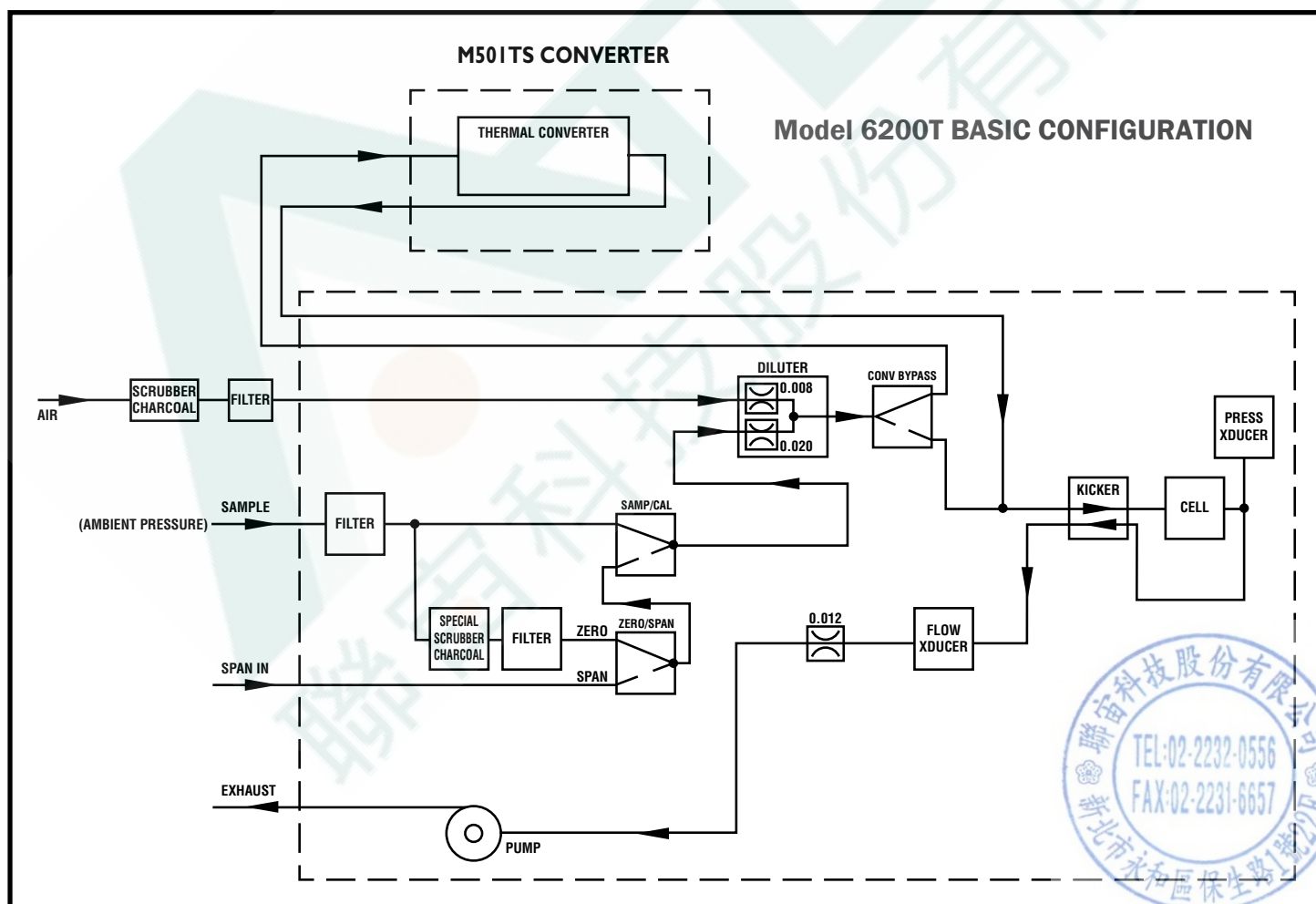

MODEL 6200T - TOTAL SULFUR ANALYZER

ELECTRONICS PLATFORM

The 6200T combines the proven UV fluorescence principle with state of the art microprocessor technology to provide accurate and dependable measurement of trace levels of total sulfur. Long term stability is obtained by the use of an optical shutter to compensate for zero drift, coupled with lamp reference detector to correct for lamp drift.

The multi-tasking microprocessor allows easy field ranging from 50 ppb to 20 ppm as well as providing on-line indication of instrument status. The 6200T continuously checks operating parameters and provides alarms on out-of-specification conditions, including electrical and optical parameters.

The T-series utilizes a capacitive, color touch-screen with menu-driven functionality and large interface for ease of use. The upgraded electronics also offer a variety of electrical I/O including Ethernet, USB ports, 4 configurable analog outputs, two RS-232 channels and several digital inputs and outputs, with additional I/O optionally available. Data-acquisition capability is included as standard.

I/O

- 4 x settable voltage or 4-20mA analog outputs
- 2 x RS-232 digital outputs
- Ethernet port
- USB ports
- 8 opto-isolated digital outputs
- 6 opto-isolated digital inputs
- Optional USB communications, RS-485, analog input channels, multidrop RS-232

THE COMPONENTS

The 6200T comes complete with three 19 inch relay rack modules - the Sample Converter Module, the Analysis Module, and a Calibration Module.

- The Sample Converter Module comes with an SO₂ scrubber, sample / ambient air filters, high temperature dilution control orifice box, and Total Reduced Sulfur (TRS) converter.
- The Analysis Module consists of the UV fluorescence analyzer, pressure and flow transducers, and vacuum pump.
- The optional Calibration Module consists of restrictor / orifice flow regulators and flow control system, all provided in a temperature controlled setting to ensure accurate performance. The two inlet ports allow use of two independent calibration gases which may be diluted to provide the required span gas concentration. Dilution ratios from 20:1 to 300:1 are manually set from the front panel.

Ask Teledyne...

about analyzers to measure other trace impurities in carbon dioxide.

- Benzene
- Acetaldehyde
- Hydrocarbons
- Moisture
- Carbon Monoxide
- NO_x
- Ammonia
- Oxygen
- Methanol

Or we can make you a turnkey CDQC system to measure some or all impurities!



MODEL 6200T - TOTAL SULFUR ANALYZER

SPECIFICATIONS

Ranges	Min: 0-50 ppb Full scale Max: 0-20,000 ppb Full scale (selectable,dual ranges and auto ranging supported)
Measurement Units	ppb, ppm, $\mu\text{g}/\text{m}^3$, mg/m^3 (selectable)
Zero Noise	< 0.2 ppb (RMS)
Span Noise	< 0.5% of reading (RMS) above 50 ppb
Lower Detectable Limit	0.4 ppb
Zero Drift	< 0.5 ppb/24 hours
Span Drift	< 0.5% of full scale/24 hours
Lag Time	20 seconds
Rise and Fall Time	< 100 seconds to 95%
Linearity	1% of full scale
Precision	0.5% of reading above 50 ppb
Sample Flow Rate	$650 \text{ cm}^3/\text{min} \pm 10\%$
Power Requirements	100V-120V, 220V-240V, 50/60 Hz
Analog Output Ranges	10V, 5V, 1V, 0.1V (selectable)
Recorder Offset	$\pm 10\%$
Operating Temperature Range	5 - 40°C
Dimensions (H x W x D)	Analyzer: 7" x 17" x 23.5" (178 x 432 x 597 mm) Converter: 7" x 17" x 22" (178 x 432 x 559 mm)
Weight	Analyzer: 35.7 lbs (16.2 kg) Converter: 24 lbs (10.8 kg)

聯宙科技股份有限公司
Atlas Tech. Corp.
www.atlasgroup.com.tw

地址: 台灣新北市永和區保生路一號22樓
Add: 22F., No.1, Baosheng Rd., Yonghe
Dist., New Taipei City 23444, Taiwan

Tel: +886.2.2232.0556
Fax: +886.2.2231.6657
atlas@atlasgroup.com.tw

